

NASA/CR—2004-213312



Asymmetrical Capacitors for Propulsion

Francis X. Canning, Cory Melcher, and Edwin Winet
Institute for Scientific Research, Inc., Fairmont, West Virginia

October 2004

The NASA STI Program Office . . . in Profile

Since its founding, NASA has been dedicated to the advancement of aeronautics and space science. The NASA Scientific and Technical Information (STI) Program Office plays a key part in helping NASA maintain this important role.

The NASA STI Program Office is operated by Langley Research Center, the Lead Center for NASA's scientific and technical information. The NASA STI Program Office provides access to the NASA STI Database, the largest collection of aeronautical and space science STI in the world. The Program Office is also NASA's institutional mechanism for disseminating the results of its research and development activities. These results are published by NASA in the NASA STI Report Series, which includes the following report types:

- **TECHNICAL PUBLICATION.** Reports of completed research or a major significant phase of research that present the results of NASA programs and include extensive data or theoretical analysis. Includes compilations of significant scientific and technical data and information deemed to be of continuing reference value. NASA's counterpart of peer-reviewed formal professional papers but has less stringent limitations on manuscript length and extent of graphic presentations.
- **TECHNICAL MEMORANDUM.** Scientific and technical findings that are preliminary or of specialized interest, e.g., quick release reports, working papers, and bibliographies that contain minimal annotation. Does not contain extensive analysis.
- **CONTRACTOR REPORT.** Scientific and technical findings by NASA-sponsored contractors and grantees.

- **CONFERENCE PUBLICATION.** Collected papers from scientific and technical conferences, symposia, seminars, or other meetings sponsored or cosponsored by NASA.
- **SPECIAL PUBLICATION.** Scientific, technical, or historical information from NASA programs, projects, and missions, often concerned with subjects having substantial public interest.
- **TECHNICAL TRANSLATION.** English-language translations of foreign scientific and technical material pertinent to NASA's mission.

Specialized services that complement the STI Program Office's diverse offerings include creating custom thesauri, building customized databases, organizing and publishing research results . . . even providing videos.

For more information about the NASA STI Program Office, see the following:

- Access the NASA STI Program Home Page at <http://www.sti.nasa.gov>
- E-mail your question via the Internet to help@sti.nasa.gov
- Fax your question to the NASA Access Help Desk at 301-621-0134
- Telephone the NASA Access Help Desk at 301-621-0390
- Write to:
NASA Access Help Desk
NASA Center for Aerospace Information
7121 Standard Drive
Hanover, MD 21076

NASA/CR—2004-213312

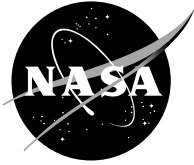

Asymmetrical Capacitors for Propulsion

Francis X. Canning, Cory Melcher, and Edwin Winet
Institute for Scientific Research, Inc., Fairmont, West Virginia

Prepared under Contract NAS3-00124

National Aeronautics and
Space Administration

Glenn Research Center

October 2004

Trade names or manufacturers' names are used in this report for identification only. This usage does not constitute an official endorsement, either expressed or implied, by the National Aeronautics and Space Administration.

Available from

NASA Center for Aerospace Information
7121 Standard Drive
Hanover, MD 21076

National Technical Information Service
5285 Port Royal Road
Springfield, VA 22100

Available electronically at <http://gltrs.grc.nasa.gov>

Asymmetrical Capacitors for Propulsion

Francis X. Canning, Cory Melcher, and Edwin Winet
Institute for Scientific Research, Inc.
Fairmont, West Virginia 26554

Abstract

Asymmetrical Capacitor Thrusters have been proposed as a source of propulsion. For over eighty years it has been known that a thrust results when a high voltage is placed across an asymmetrical capacitor, when that voltage causes a leakage current to flow. However, there is surprisingly little experimental or theoretical data explaining this effect. This paper reports on the results of tests of several Asymmetrical Capacitor Thrusters (ACTs). The thrust they produce has been measured for various voltages, polarities, and ground configurations and their radiation in the VHF range has been recorded. These tests were performed at atmospheric pressure and at various reduced pressures. A simple model for the thrust was developed. The model assumed the thrust was due to electrostatic forces on the leakage current flowing across the capacitor. It was further assumed that this current involves charged ions which undergo multiple collisions with air. These collisions transfer momentum. All of the measured data was consistent with this model. Many configurations were tested, and the results suggest general design principles for ACTs to be used for a variety of purposes.

Introduction

Prior Experiments

Sometime before entering college in 1922 Thomas Townsend Brown observed that a force is produced on a Coolidge tube when a high voltage is applied. Since then it has been found that a force is produced when a high voltage is applied to many other asymmetrical capacitors as well. Brown received multiple patents in the U.S. and one in Great Britain for his work^{1, 2, 3}. This effect is called the Biefeld-Brown Effect; it was discovered while T. T. Brown was in graduate school, working under his advisor, Dr. Paul Alfred Biefeld. While it is generally accepted that such an asymmetrical capacitor produces a thrust, there is not a similar agreement on the mechanism responsible for the force produced. The purpose of this paper is to provide new test results and an analysis of those results to resolve this question.

Beginning with the work of T.T. Brown, there is a long history of interest in these devices. In one configuration, two asymmetrical capacitors are arranged to rotate about a vertical axis. This device is generally called an Asymmetrical Capacitor Thruster (ACT). Another common configuration involves one capacitor plate above the other, arranged so the device can lift off the ground. This device is called a lifter. Alexander de Seversky investigated lifters during the 1960's with his "Ionocraft" and received a U.S. patent.⁴ De Seversky's craft combined a series of wires perpendicular to a mesh plate to lift the device.

Robert Talley of Veritay Technology⁵ performed tests of ACTs in a vacuum in the late 1980's under Air Force contract. The tests did not let the ACTs spin, but instead suspended it from a torsion wire. This gave him the sensitivity to be able to measure small forces. His report is the only written report we have found from the last half-century that describes a measurement of a force while in a vacuum chamber. Talley ultimately attributed the force that he observed to the electrostatic interaction between the chamber and the device. Talley wrote, "Direct experimental results show that under high vacuum conditions... no detectable propulsive force was electrostatically induced by applying a static potential difference... between test device electrodes..." Talley concluded (page 91 of his report⁵), "If such a force still exists and lies below the threshold of measurements in this program, then the force may be too small to be attractive for many, if not most, space propulsion applications." While this work makes a strong case against the ability of these devices to produce a force in a vacuum, it did not address the use of asymmetrical capacitors in the atmosphere.

Interest in ACTs and lifters continues today. Jonathan Campbell of NASA's Marshall Space Flight Center has designed and tested ACTs that use dielectrics to increase their thrust, receiving U.S. patents^{6,7} for this work in 2001 and 2002. Thomas Bahder and Chris Fazi of the Army Research Lab (ARL) in Adelphi, MD have recently reported work on the subject⁸. They constructed multiple devices, both original and reproductions of designs found on the internet and made qualitative observations. Bahder and Fazi's paper includes a brief history and an attempt at an explanation of the cause of the force observed. However, they conclude that "At present, the physical basis for the Biefeld-Brown effect is not understood." J.L. Naudin⁹ and others have constructed devices similar to the original Brown patent, and then assembled multiple devices into larger designs to create "lifters" that perform similarly to de Seversky's craft. These designs vary greatly in size and shape; some are multiple cells or have stacked layers of cells, to create more efficient and more powerful devices.

Present Approach

In spite of all of this attention, there is no clear consensus on how a force is produced. There is a surprising lack of information on this subject in peer reviewed journals. Given this situation, and the prevalence of speculation from a variety of other sources, we performed an experimental and theoretical study. Our primary goal was to make careful measurements and to see if they could be explained by well known physical principles. Our secondary goal was to understand this device as an "engine" that produces thrust, and to learn how to improve its efficiency.

It should be noted that in sources other than peer reviewed journals, there is a large number of explanations for the operation of lifters. Some of these explanations suggest that such devices should work in a vacuum, and many involve mechanisms that seem to violate accepted physical principles. We took data and developed a simple theory, based on well-known (elementary) physical principles. The comparison of theory and data was often qualitative, but numerical simulations were also used. These simulations were designed to elucidate the causes of some specific features of the experimental data. All of the experimental data was found to be consistent with the theory and numerical simulations. According to Occum's Razor, the simplest explanation is the best. In that context, we note that our model was simple and was based on well

known physical principles, and it was sufficient to explain all of our data and the data we have found in the literature.

Some Proposed Theories

The operational characteristics of ACTs and lifters provide some clues as to how they produce thrust. Various size and shape devices generally require a voltage ranging from a few kilovolts to 100 kilovolts or more to produce a measurable force. The asymmetry of the devices is widely accepted as instrumental in allowing a force to be produced. For most designs (but not for all, as our test data below shows) the direction of the force is independent of the polarity of the applied voltage, but instead depends on the asymmetry of the capacitor.

Several theories have been proposed to explain the thrust produced by asymmetrical capacitors. Due to the lack of prior articles in peer reviewed journals explaining this thrust, proposed theories from a variety of sources will be noted here. These theories involve mechanisms such as ablative material on the capacitor surface, polarizing the vacuum into matter and antimatter, and electrostatic forces.

Ablative material will be discussed below. However, as a preview it may be mentioned that for the velocities of the ejected material that might be expected to result from thermal or electrostatic forces, the amount of material that would need to be removed is much greater than that available. The suggestion of polarizing the vacuum into matter and antimatter appears inconsistent with known physics, since the energy available at the particle level, due to an ACT, is roughly 9 orders of magnitude too small. These proposed mechanisms are discussed in more detail under “Theoretical Analysis.”

Another class of theories involves electrostatic forces. A thrust might be produced due to the charges on the ACT interacting with either charges on nearby bodies or with charges comprising the leakage current produced by the ACT itself. For example, even in a vacuum chamber, the ACT might interact with charges induced on the walls of that chamber. Static charges on the ACT might interact with induced charges on metal or dielectric objects near the chamber. A related explanation uses the fact that for some configurations the leakage current flows in bursts called Trichel Pulses¹⁰. These bursts radiate, and they can create a varying charge on nearby conductors. It is possible that such a charge might interact with the charge on the ACT, and produce a force.

In isolation (i.e., in a vacuum) the interaction of the charge on the ACT with its own leakage current cannot produce a net thrust. Charged particles leaving one plate accelerate and electrostatic forces transfer momentum to the capacitor. However, when these charged particles reach the other plate, they transfer the opposite amount of momentum to the capacitor, and there is no net effect. However, in the atmosphere this can produce a thrust. Ions in the leakage current undergo multiple collisions with the air before reaching the other plate. These collisions transfer momentum to the air, and the net effect is that an equal but opposite amount of momentum is transferred to the ACT. This explanation says that the direction of current flow (defined as the direction of net positive charge flow) is not as significant as the direction that charge carriers actually move (regardless of the sign of their charge). This would suggest that

the asymmetry of the device is more important than the polarity of the applied voltage, in agreement with our observations and those of others.

Tests Performed

Experiments were designed to evaluate several proposed theories. Four different capacitor designs were tested. The initial tests took place in a rectangular wooden enclosure. Its interior was covered by aluminum and grounded. Later, tests were performed in a stainless steel vacuum chamber with the same dimensions. Each of the four different devices tested included a disc and a hollow cylinder, as shown schematically in figure 1.

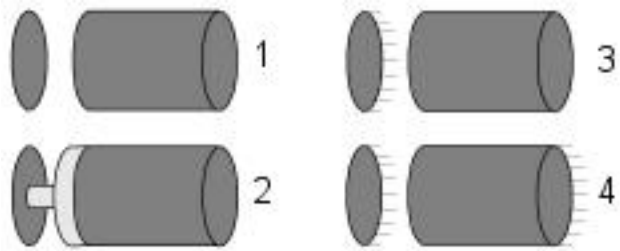

Figure 1 - Schematic of the four devices tested.

All four devices were mounted in pairs on opposite sides of a vertical axis. Figure 2 shows Device 1, which consists of a copper disc mounted coaxially to a hollow copper cylinder and separated by approximately 2.5 inches.

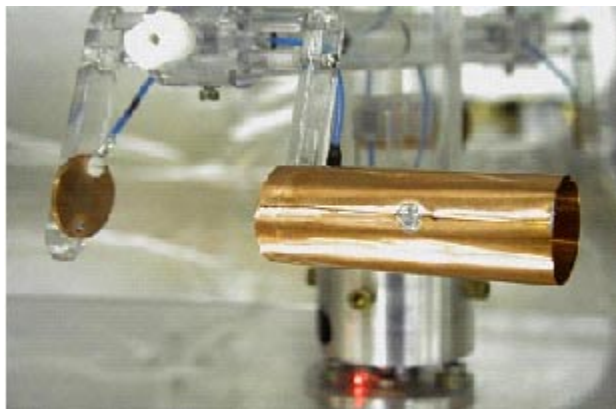

Figure 2 - Device 1 mounted on rotation assembly

Device 2 included the copper disk and cylinder of Device 1, and in addition contained a dielectric in the gap between the 2 electrodes, as shown in figure 3.



Figure 3 - Device 2

Device 2 was used to show the effects of dielectric material. Devices 3 and 4 do not contain any dielectric material, but rather they are designed to show the effects of additional asymmetry. The asymmetry of Device 1 lies in the fact that the edges of the disk may be considered more of a sharp edge than the edges (ends) of the cylinder (this is made more precise by our numerical simulation, see fig. 7 below). One hypothesis tested was that currents may more easily flow from such sharp features. To test this, Devices 3 and 4 have a rounded collar on the edge of the cylinder nearest to the disk. The thickness of this collar is several times the wall thickness of the cylinder with an inner radius of 0.016 m and an outer radius of 0.018 m for Device 3 and inner and outer radii of 0.017 m and 0.022 m respectively for Device 4. The collar on Device 4 extends 0.004 m axially along the cylinder, while the collar on Device 3 only extends 0.002 m. In addition to this smoothing of the cylinder, the disk in Devices 3 and 4 is given an additional sharp feature. Multiple sharp wires are attached to the edge of the disk, and they point towards the cylinder. These wires are made of aluminum, and they are taken from a screen intended to be used in a window screen in a home. Device 4 was distinguished from Device 3 in that in addition to these features, Device 4 also had short aluminum wires on the edge of the cylinder most distant from the disk.

Two of each device were constructed, and each pair was mounted the ends of a horizontal arm. The horizontal arm was supported by a vertical column free to rotate on bearings. The column bearings were mounted to the inside of a rectangular structure, closed on the ends and open on the sides. The rotating assembly and the surrounding structure were made almost exclusively of Lexan[®] in order to electrically insulate the devices from the surroundings and to prevent out-gassing that could influence test results when under vacuum. Lexan[®] also allowed for quick manufacturing of the system with minimal waste. Figure 4 gives a schematic of the rotating column, horizontal arm and support structure.

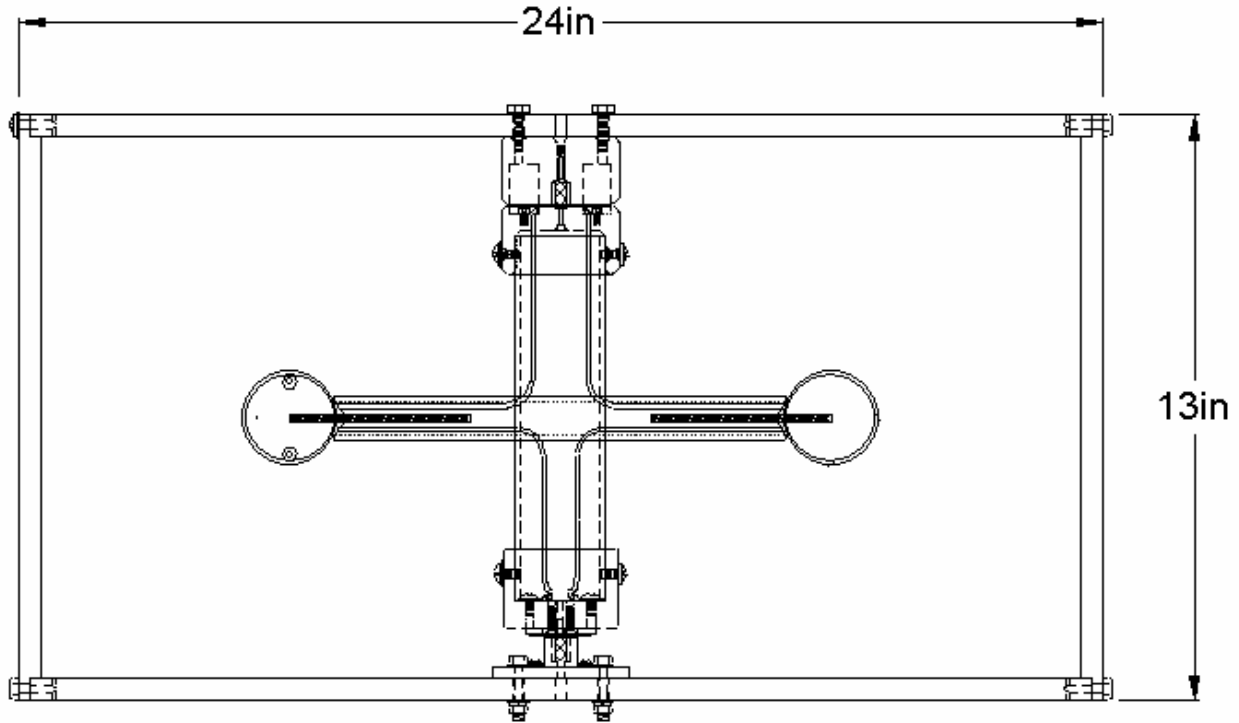

Figure 4 - Test setup with rotating portion and support structure

The rotation of the vertical column was measured using a laser which reflected off of a six sided mirror near the bottom of that column. Each time the column made one revolution, six pulses of the reflected laser light were counted at a photodiode. This allowed the rotation rate and the angular acceleration to be computed. The moment of inertia of the assembly was measured using a torsion pendulum. Also, spin down tests were performed, which involved measuring the deceleration of the device when the driving force was removed. This provided the angular deceleration as a function of angular velocity. Using the moment of inertia, it was simple to compute the frictional torque as a function of angular velocity. Details of these measurements will be given in a conference paper.

The experimental procedure was to run each device until it attained its maximum angular velocity. For that particular device (mounted on each end of the horizontal arm) and for that angular velocity, the frictional forces were then found using the spin down tests and the moment of inertia for that device. It was then assumed that the driving force was equal to the frictional force when the device was running at a constant angular velocity.

Four different configurations (A through D) were used. The four configurations result from two choices of polarity for the applied voltage and two choices for the location of the ground. These configurations are illustrated in figure 5.

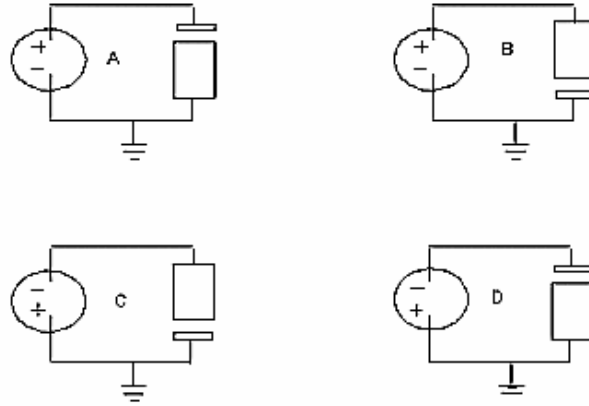

Figure 5 - Schematic of the four wiring configurations.

In our laboratory preliminary tests of Devices 1 and 2 were conducted in the aluminum lined wooden box. For these initial tests there was no control over the atmosphere (e.g. the relative humidity) surrounding the devices. All four devices were then tested under different vacuum levels, in both dry air and nitrogen while in the vacuum chamber. Device 4 was also tested under multiple pressures in an argon environment in the chamber.

The vacuum chamber used measures 36" × 50" × 72" and is located at Pittsburgh Materials Technology Incorporated in Pennsylvania. In addition to three viewing ports, the chamber was equipped with sufficient ports to allow high voltage wires to pass through in addition to another port which the antenna lead was fed through. To conserve space, further details of the experimental procedure will be given elsewhere, as will results for using gasses other than air.

Observations

Much of the data described below was taken from tests in the vacuum chamber. The test procedure was to first pump down to a high vacuum (better than 10^{-4} Torr), and to then raise the pressure in steps by inserting dry air.

Each time measurements were performed in a partial vacuum, one person was assigned to observe through a viewing port. This was important since our equipment could not measure a rotation of less than a sixth of a turn. Our experimental design was not optimized to measure a very small force, since a maximum voltage of 50 kV was applied to the ACT and since we did not use a device such as a torsion pendulum, which would have allowed the measurement of smaller forces.

After several days of tests, we found that no device showed signs of rotation at a pressure less than 300 Torr, with one exception. When Device 2 wired according to Circuit A was placed in the chamber and immediately pumped down to a pressure of 5.5×10^{-5} Torr, something interesting happened. The voltage on it was increased to 44 kV, and through the viewing port a large arc was observed. At that same moment, the device was seen to move about an eighth of a rotation and stop.

The large arc that was observed suggests that this movement was most likely caused by material being ejected from the device. This material might be either the copper on the plates or it might be water vapor. Each time the chamber was opened and then pumped down to a high vacuum, for a period of about thirty minutes the pump would frequently cycle on and off. We attributed this to water vapor and other impurities attaching themselves to all of our equipment in the chamber while it was open to the room environment. It may be significant that the large arc and slight movement occurred during the time these impurities were being removed. The amount of material that would be necessary to cause this slight one time movement would be hard to detect. (The case of continuous operation is discussed under “Ablative Material” below.)

All tests were performed by increasing the voltage slowly and observing the resulting motion. Generally, some motion (less than a tenth of a rotation) would be observed at an intermediate voltage, and then after a significant further increase in voltage rotation would begin again. It was very clear that the air in the test fixture was becoming charged. One could feel this on the hairs on their arm after a test was run. This apparently affected the operation of the ACTs.

The devices generally only rotated in one direction, the direction so that the disk was in front. However, there were some exceptions, as described in this paragraph. Device 1 was tested in air at approximately atmospheric pressure for the four configurations, Circuits A, B, C, and D (see fig. 5). For all four cases the voltage used was about 34 kV. Circuits B and C spun “backwards.” Circuit B turned at 4 RPM for a while, and then stopped. After fresh air was supplied it again spun at a slow speed. Circuit C only moved a half a turn, and then stopped. Circuits A and D rotated “forwards,” meaning the disk led the motion. Circuit D moved only a part of a rotation, while Circuit A attained 24 RPM and higher speeds on repeated tests. Device 2 Circuit B also showed some slight one time “backwards” motion.

Through the course of this testing, a few patterns became very apparent. All of the devices that rotated forwards moved faster when the cylinder was grounded (i.e. Circuit A was preferred over C and D over B.) Comparing Devices 1 through 4 with the cylinder grounded, Device 4 turned the fastest with a negative voltage on the disk (Circuit D), while all other devices turned the fastest with a positive voltage on the disk (Circuit A).

Table 1 below gives some quantitative information regarding Devices 3 and 4 wired according to Circuits A and D, and run at atmospheric pressure. For each combination, four quantities were measured. The “Voltage Applied” is the magnitude of the voltage applied to the disk. For these cases, the cylinder was kept at ground, as was the stainless steel box forming the vacuum chamber walls. The “Current Across ACT” is the current that flowed through the rear electrode (the cylinder). The “Total Current” is the current passing through the disk. These currents differ since some current may flow through the charged air in the chamber. The final number is the maximum rotation rate (in RPM) that was achieved after the device was allowed to run for about a minute.

TABLE 1

Device Number	Circuit Letter	Voltage Applied, (kV)	Current Across ACT, (micro Amps)	Total Current, (micro Amps)	RPM
3	A	40	220	240	110
3	D	39	89	115	90
4	A	42	130	160	128
4	D	46	307	340	138

Measurements were also made of VHF radiation from the ACT. This radiation was expected, since the current often flowed in bursts called Trichel pulses. We found that when the ACT was immersed in argon or nitrogen the current did not flow in bursts and such radiation was not received. However, our results suggested that, nevertheless, a similar force was produced in argon and nitrogen. This suggests that whether the current flows in bursts or not is not essential to the operation of the device.

Some Device/Circuit combinations showed rapid rotation at pressures ranging from 300 Torr to atmospheric pressure. They all rotated more slowly as the pressure was decreased. However, all of these devices were designed with a gap just large enough to prevent arcing at atmospheric pressure for voltages just below the largest voltage we could produce, 50 kV. Using this criteria and well known formulas, one could optimize the design for lower pressures. For example, one could increase the distance between electrodes as the pressure is decreased. In addition, the asymmetries due to sharp edges (such as the wires used in Devices 3 and 4) also produce additional thrust.

Theoretical Analysis

Ablative Material

Ablation of the electrodes produces charged particles. If we assume that these charged particles have the thermal energy associated with electrodes which cause arcing, these particles would have the following speed:

$$\bar{v} = \left(\frac{8kT}{\pi m} \right)^{1/2} \quad (1)$$

where k is Boltzmann's constant, T is temperature, and m is mass of the particle. For a copper electrode the temperature of the electrode is likely to be on the order of 2600 K. Substituting this temperature, the mass of a copper atom, and Boltzmann's constant into the above equation gives:

$$\bar{v} = \left(\frac{8 \times \left(1.3807 \times 10^{-23} \frac{J}{K} \right) \times (2600 \text{ K})}{\pi (1.0544 \times 10^{-25} \text{ kg})} \right)^{1/2} = 930 \text{ m/s} \quad (2)$$

If these atoms or ions are assumed to travel directly from one electrode to the other, the mass flow rate at this velocity associated with a given force is:

$$\frac{dm}{dt} = \frac{F}{v} \quad (3)$$

Using a force observed for one of our test devices, and the speed calculated above:

$$\frac{dm}{dt} = \frac{0.014 N}{931.1 m/s} = 1.5 \times 10^{-5} kg/s \quad (4)$$

This means that the smaller electrode, which initially weighed roughly 0.005 kg would be completely ablated 10 times over in one hour of testing. As no signs of degradation of the electrode were visible, even after repeated testing, this mechanism cannot be occurring on this scale or creating a large portion of the force produced. Thus, we conclude that removal by heat due to events such as sparks cannot explain an appreciable part of the forces that were observed during steady state operation. It could, however, explain infrequent events associated with a slight motion.

Polarizing the Vacuum

Various web sites provide a variety of explanations for the thrust produced by lifters. Explanations vary from electrostatic effects¹¹ to “an interaction between the high-voltage components of the Lifter and the surrounding vacuum-properties of the environment,” as suggested by the American Antigravity Organization¹². Such an explanation, were it true, might also provide hope that lifters and ACTs could provide a propulsive force in a vacuum. Our data did not show any evidence for forces in a vacuum. More importantly, we note that the electrostatic forces of our devices are many orders of magnitude too small to achieve this result. For instance, the accelerator at CERN can achieve energies up to a terra electron volt. With these energies, it is possible to create matter and antimatter from pure energy.

The energy to create an electron-positron pair is about a Mega Electron Volt (this is $2mc^2$ using the mass of an electron for m). Although the work done on an electron in moving across an ACT can be 100 keV, it is not appropriate to compare that number to the Mega Electron Volt. This work is done over centimeters while the relevant comparison is the work done on an electron within an atomic length scale or smaller (such as angstroms or less). Over a one angstrom gap, the available energy is less than a billionth of a Mega Electron Volt. This calculation suggests that this mechanism is not viable, and our experimental data does not provide any evidence for it.

Electrostatic Forces without Current Flow

One possible explanation for lifters might be electrostatic forces due to a net charge on the lifter interacting with induced charges (e.g. image charges) in the ground below. Lifters use a stationary power supply, and how it is configured determines if there is a net charge on the lifter (note the ground can be wired in different ways, and some examples are illustrated in figure 5 above). To investigate this possibility, assume the extreme case of a perfectly conducting ground

plane below a lifter, and also assume that its distance from the lifter is one hundred times the distance between the charged plates of the lifter. If one plate is at ground and the other is at a voltage such as 100 kilovolts, then the electrostatic force between the lifter and an image charge is significant. Computations show it is about the magnitude necessary to lift the lifter. However, this force is attractive, so it would pull the lifter down, not push it up.

The power supply could be configured so that the lifter has zero net charge. That is, one plate could be positively charged and the other negatively charged, giving zero net charge. This gives the electrostatic field of a dipole. If there were a perfectly conducting ground plane below such a lifter, then an image dipole would be induced. The resulting force would be reduced from that discussed above by a factor of one hundred squared, since each dipole would give a field about one hundred times smaller than a single charge. However, using a dielectric of relative dielectric constant one hundred would increase the force by a factor of one hundred squared. This force would then be of about the magnitude that lifters experience. However, the force between a dipole and its image is attractive, so it would be a downward force.

These effects are not likely to be significant for actual lifters, since grass and even a concrete floor (possibly with rebar in it) is not a good conductor. These effects may be more relevant for ACTs which may operate near metal objects. However, when an ACT rotates within a metal box, these effects may be expected to average to zero. These devices create a dipole like field for all distances larger than a few times the distance between their electrodes. This field is the same in front of the device as behind it, except for a change of sign. This symmetry causes a nearly total cancellation of forces for a rotating device. We note that Talley's experiment did not rotate, but instead suspended the device from a stiff wire. Since that did not rotate, his design was susceptible to electrostatic effects, as he reported.⁵

There are other plausible mechanisms for creating an electrostatic force. For example, accelerating charges radiate. When this radiation is incident on a conductor (or dielectric), it can cause a current. If the current and charge on the ACT were non uniform (as happens, for example, when there are Trichel Pulses), then there could be an induced charge and a resulting electrostatic interaction. We expect that such an effect would be quite small. Any charges that accelerate also decelerate, either by collisions with air the other electrode. These effects tend to cancel, so the net result should be quite small. Also, our experimental data using Argon show the ACT still produces a force, which depends on the current, and voltage in a similar way to in air. However, in Argon the current flows uniformly, and not in bursts. Thus, since this mechanism would not give a force in argon, we conclude that it is unlikely to be significant.

Electrostatic Forces with a Current Flow

A simple model was found to explain all of our data. The thrust produced can be explained by electrostatic forces moving ions, and by those ions transferring their momentum to the surrounding air by collisions. Using some reasonable approximations, this force can be easily computed. Later, some of those assumptions will be removed and the calculation made more accurate. We assume for now that all of the current consists of N_2 ions traveling directly from one electrode to the other, and further assume that the voltage changes uniformly from one

electrode to the other. Furthermore, we assume that all of the ions move from one electrode to the other. That is, all of the ions have the same charge and move in the same direction.

With these assumptions, the Force F may be computed in terms of the total charge, q , the Voltage applied, V , and the distance between electrodes, d , as

$$F = qE = qV/d = tIV/d \quad (5)$$

This force is repulsive between the charge of the ion source and the ions that are moving between the electrodes. The total charge between the plates is given by the current flowing times the time it takes to travel between the plates. Assuming that at atmospheric pressure in air there are 10^{10} collisions per second, and that each collision on average stops a moving ion, we find that the distance between collisions in terms of the mass of an ion, m , is

$$d_0 = (1/2) a t_0^2 = (1/2) a [10^{-10} \text{ sec}]^2 \text{ where } a = F/m = [eV/d]/m \quad (6)$$

The total time t to travel a distance d is then

$$t = 10^{-10} \text{ sec } (d/d_0) = 2d (10^{10}/\text{sec})/a = 2d^2 10^{10} \text{ sec } m/(eV) \quad (7)$$

Substituting (7) into (5) gives

$$F = 2 d (10^{10}/\text{sec}) m I / e \quad (8)$$

$$F = \frac{2(7 \text{ cm})(4.7 \times 10^{-26} \text{ kg})}{1.6 \times 10^{-19} \text{ Coul.}} (.0035 \text{ Amps}) \times 10^{10} / \text{sec} = 1.44 \text{ Nt.} \quad (9)$$

Now, some of the assumptions made above will be removed. One type of lifter uses a vertical metallic strip, and a wire above that strip. As ions move away from that wire, the electric field directs the ions towards the larger electrode, the metallic strip. A simulation of this device has been computed, and is shown in figure 6. Since each side of a lifter is relatively long (compared to the other two dimensions), it is modeled as a two dimensional object.

Because of the multiple collisions with air, momentum is not significant and the ion's paths are taken to be along the electric field lines. The ion's speed at each location is proportional to the strength of the field at that location. In figure 6 the ion's paths are shown in grey and the lifter is shown in black. This simulation is computed assuming that the metallic strip is at the same voltage as ground, which is different from the voltage of the wire. This simulation took into account forces between the ions and the electrodes of the lifter. It did not take into account the forces the ions exerted on each other.

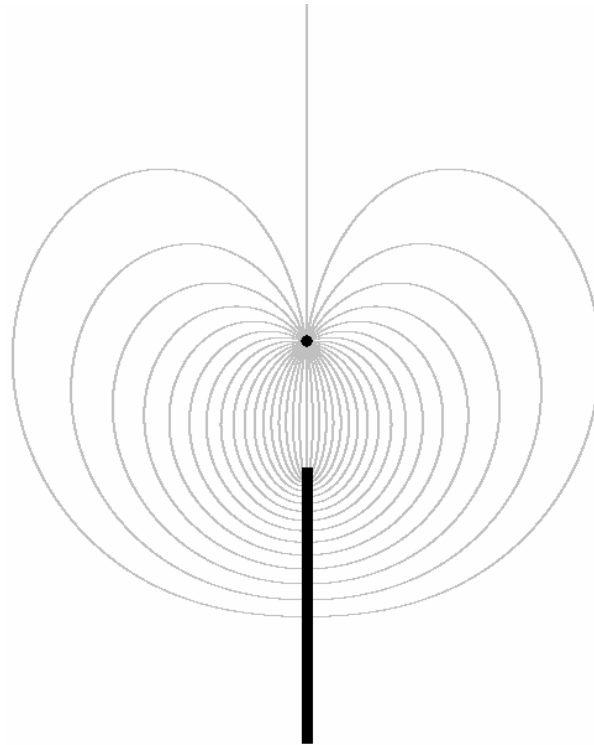

Figure 6 - Paths of ions emitted from lifter style asymmetrical capacitor.

Equation 9 gave a formula for computing the thrust produced by a lifter or an ACT. It assumed that everything functioned perfectly, and as such represents the maximum thrust that could be produced. For example, it did not consider the possibility that some ions would move in the opposite direction, which would decrease the net force somewhat. Also, the derivation of that formula assumed that all ions took the direct path between the electrodes. In figure 6, that would be the path straight down from the wire to the strip. However, for the lifter of figure 6 one would expect that ions are produced equally in all directions around the wire (since very close to the wire, the electric field is radial, and approximately equally strong in all directions).

One could ask if the paths that are less direct produce more or less force than the direct path. Our numerical computation showed that a given current flowing along a path produces a contribution to the total thrust which is proportional to the vertical extent of that path. Averaging over all paths, we found that for this lifter geometry the total force would be increased by 38% above that computed in equation 9.

This numerical result for the total impulse produced by an ion moving from one plate to the other can also be found by a simple argument. An ion travels at a drift velocity, s , which varies according to the local applied force according to the proportionality,

$$s = \alpha F \tag{10}$$

Since an ion moves a vertical distance dh , which is related to the time it takes to move that distance, dt , by the formula

$$dh = s dt \quad (11)$$

one finds that the impulse produced when an ion moves a distance dh is

$$\int F dt = \int F dh / s = \int F dh / (\alpha F) = \int dh / \alpha \quad (12)$$

Thus, the total impulse produced over a path is proportional to the sum of dh , or the total vertical extent of that path. This mathematical model shows that the force produced by each ion is directly proportional to the linear distance traveled along the plane of the device towards the plate, in agreement with the numerical simulation.

Device 4 for Circuit A generated the most force for the power consumed. Using equation (9) to compute the force, we find the force is 77% of that measured. This computation used the direct across distance between the disk and the near end of the cylinder. Due to the uncertainties, of current flowing in both directions decreasing the force, and of the argument of figure 6 increasing it, this agreement is quite good.

There are several qualitative but distinctive features of the experimental results. They may be summarized by noticing several patterns. The less symmetric devices, Devices 3 and 4, always ran in the same direction, for all four circuits (A through D). The more symmetric devices, Devices 1 and 2, showed movement in a direction that depended on the location of the ground, but not on the polarity. That is, Circuits A and D ran forwards, while B and C ran backwards. This may be explained by a physical argument, which is supported by numerical modeling.

Consistent with the ion drift model for the force produced, there must be a source of ions. When ions are produced by one plate of the capacitor, they will have the same charge as that plate and will repel it. As a result, the device should turn with the plate producing ions (or producing more ions) in front. The needles in the disk in Devices 3 and 4 produce a strong local electric field, that is likely to be a significant source of ions. Thus, it is expected that that Devices 3 and 4 should turn faster than Devices 1 and 2 as we observed, and it also is expected that the disk should be in front, as we also observed.

To explain the behavior of Devices 1 and 2, we need to understand how these devices produce ions. The basic physical reason is the same reason why charged sharp objects have a high electric field. As a thought problem, consider an isolated straight thin wire held at a potential of one volt. The charges within the wire are all in equilibrium, so the electrostatic forces pushing them along the wire must cancel out. Very near either end of the wire, say the right end, the repulsion from all of the charges to the left must cancel the repulsive force from the charges to the right. Since there is little room to the right, there must be a high charge density there. This is a well know effect. It explains why charged sharp objects such as needles have a high electric field near them. In addition, it explains the operation of Devices 1 and 2

Devices 1 and 2 rotate in a direction which depends on which surface is grounded, which certainly makes sense. It is only the charged surface that generates a strong electric field near it. Also, when the cylinder is grounded and the disk charged, more thrust is generated than when the

disk is grounded and the cylinder charged. This could be explained if putting the disk at a voltage produces a stronger field near it than the field produced near the cylinder when it is placed at the same voltage. It makes sense that since the interior end of the cylinder (the end near the disk) is in the middle the voltage should be smoother there producing less electric field, as compared to near the disk. These arguments are suggestive only, but they may be verified by numerical modeling.

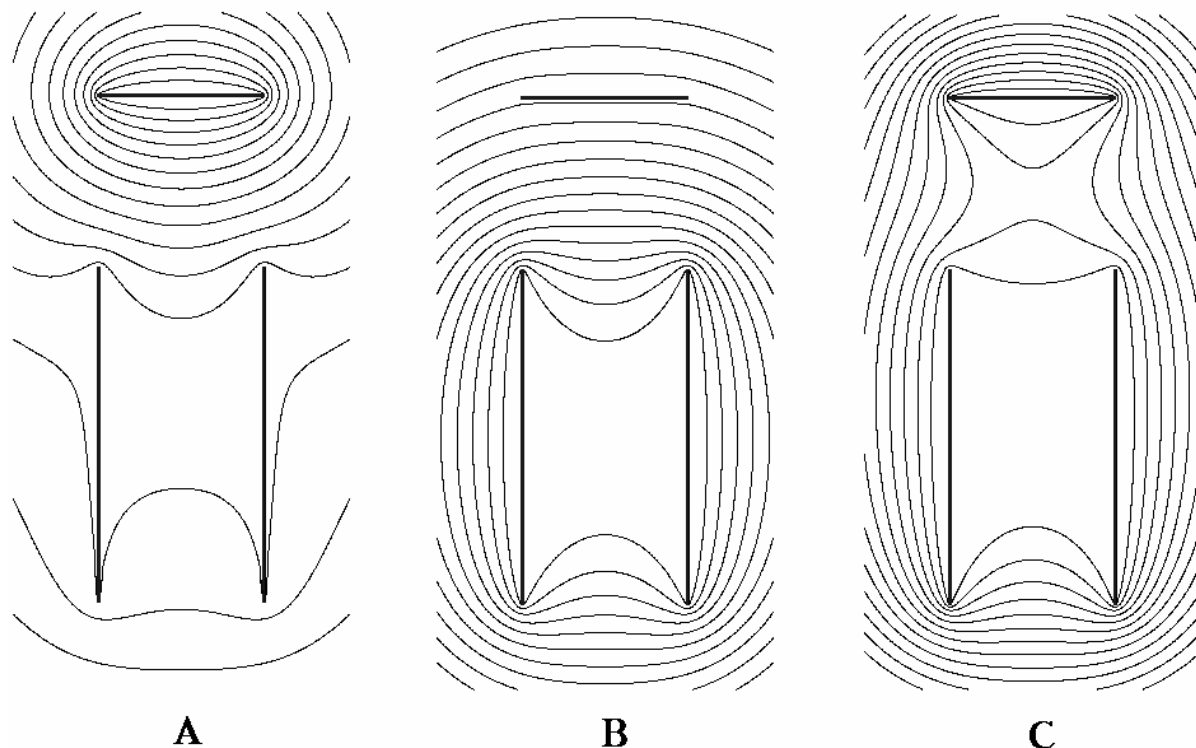

FIGURE 7. Equal voltage contour lines for a two dimensional model of Device 1, with the front plate (disk) charged (A), the rear plates (cylinder) charged, and with both held at the same voltage from ground (C).

A simple two dimensional version of the disk and cylinder was modeled. It is expected that features, such as how fields at interior and exterior edges differ, will be the same in two and three dimensions. The results the model are shown in figure 7. In part A, the “disk” was charged, and the “cylinder” was held at ground. Not surprisingly, there is a strong electric field near the disk, as shown by the closely spaced voltage contours near it. In part B, the cylinder is charged while the disk is held at ground. A strong electric field results near the interior edge of the cylinder. This explains why the device rotates “backwards” for Circuits B and C. One can also see from figure 7 that the electric field is stronger near the disk when it is charged (see Part A) than it is near the cylinder when it is charged (see Part B). In fact, numerically we found the ratio of strengths to be almost two to one. This agrees with our observations that that the device rotated much faster (in the forward direction) for circuits A and D than it rotated (backwards) for circuits B and C.

Conclusions

A series of careful tests have been performed on Asymmetrical Capacitor Thrusters (ACTs). In the past, several mechanisms have been proposed for the thrust that they produce. These mechanisms were considered, both on theoretical grounds and by comparison with test results. All of the mechanisms considered were eliminated except one. A simple model was developed of ions drifting from one electrode to the other under electrostatic forces, and imparting momentum to air as they underwent multiple collisions. This model was found to be consistent with all of our observations. It predicted the magnitude of the force (thrust) that was measured. It also predicted how the direction of the thrust changed when the location of the ground wire changed. Furthermore, it also predicted that the direction of the thrust was independent of the polarity of the applied voltage. Finally, it qualitatively predicted how the magnitude of the thrust varied as the design of the ACT (its shape, etc.) varied, over many such design changes. It may be concluded that the ion drift model explains how a thrust is developed by ions pushing on air. Tests were also performed in nitrogen and argon, and were performed at reduced pressures. A thrust was also produced at moderately reduced pressures, when the ACT produced a current flow without causing a breakdown of the air or other gas. In spite of decades of speculation about possible new physical principles being responsible for the thrust produced by ACTs and lifters, we find no evidence to support such a conclusion. On the contrary, we find that their operation is fully explained by a very simple theory that uses only electrostatic forces and the transfer of momentum by multiple collisions.

References

- ¹ Brown, T.T., US Patent 2,949,550, "Electrokinetic Apparatus," 1960.
- ² Brown, T.T., US Patent 3,187,206, "Electrokinetic Apparatus," 1965.
- ³ Brown, T.T., GB Patent 300,311, "A Method of and an Apparatus or Machine for Producing Force or Motion," 1928.
- ⁴ de Seversky, A.P., US Patent 3,130,945, "Ionocraft," 1964.
- ⁵ Talley, R.L., "Twenty First Century Propulsion Concept," PL-TR-91-3009, 1991.
- ⁶ Campbell, J.W., US Patent 6,317,310, "Apparatus and Method for Generating Thrust Using a Two Dimensional, Asymmetrical Capacitor Module," 2001.
- ⁷ Campbell, J.W., US Patent 6,411,493, "Apparatus and Method for Generating Thrust Using a Two Dimensional, Asymmetrical Capacitor Module," 2002.
- ⁸ Bahder, T.B. and Fazi, C., "Force on an Asymmetric Capacitor—Final Report, Aug.–Dec. 2002," ARL-TR-3005, NTIS Order Number ADA416740.
- ⁹ <http://jnaudin.free.fr/>
- ¹⁰ Cobine, J.D., "Gaseous Conductors," pp. 291, Dover Publications, Inc., New York, 1958
- ¹¹ <http://blazelabs.com>.
- ¹² <http://americanantigravity.com>.

REPORT DOCUMENTATION PAGE			<i>Form Approved</i> <i>OMB No. 0704-0188</i>	
Public reporting burden for this collection of information is estimated to average 1 hour per response, including the time for reviewing instructions, searching existing data sources, gathering and maintaining the data needed, and completing and reviewing the collection of information. Send comments regarding this burden estimate or any other aspect of this collection of information, including suggestions for reducing this burden, to Washington Headquarters Services, Directorate for Information Operations and Reports, 1215 Jefferson Davis Highway, Suite 1204, Arlington, VA 22202-4302, and to the Office of Management and Budget, Paperwork Reduction Project (0704-0188), Washington, DC 20503.				
1. AGENCY USE ONLY (Leave blank)		2. REPORT DATE October 2004	3. REPORT TYPE AND DATES COVERED Final Contractor Report	
4. TITLE AND SUBTITLE Asymmetrical Capacitors for Propulsion			5. FUNDING NUMBERS WBS-22-62-949-10-01 NAS3-00124	
6. AUTHOR(S) Francis X. Canning, Cory Melcher, and Edwin Winet				
7. PERFORMING ORGANIZATION NAME(S) AND ADDRESS(ES) Institute for Scientific Research, Inc. 1000 Technology Drive, Suite 1110 Fairmont, West Virginia 26554			8. PERFORMING ORGANIZATION REPORT NUMBER E-14772	
9. SPONSORING/MONITORING AGENCY NAME(S) AND ADDRESS(ES) National Aeronautics and Space Administration Washington, DC 20546-0001			10. SPONSORING/MONITORING AGENCY REPORT NUMBER NASA CR-2004-213312	
11. SUPPLEMENTARY NOTES Project Manager, Marc G. Millis, Turbomachinery and Propulsion Systems Division, NASA Glenn Research Center, organization code 5870, 216-977-7535.				
12a. DISTRIBUTION/AVAILABILITY STATEMENT Unclassified - Unlimited Subject Categories: 20 and 70 Available electronically at http://gltrs.grc.nasa.gov This publication is available from the NASA Center for AeroSpace Information, 301-621-0390.			12b. DISTRIBUTION CODE	
13. ABSTRACT (Maximum 200 words) Asymmetrical Capacitor Thrusters have been proposed as a source of propulsion. For over eighty years, it has been known that a thrust results when a high voltage is placed across an asymmetrical capacitor, when that voltage causes a leakage current to flow. However, there is surprisingly little experimental or theoretical data explaining this effect. This paper reports on the results of tests of several Asymmetrical Capacitor Thrusters (ACTs). The thrust they produce has been measured for various voltages, polarities, and ground configurations and their radiation in the VHF range has been recorded. These tests were performed at atmospheric pressure and at various reduced pressures. A simple model for the thrust was developed. The model assumed the thrust was due to electrostatic forces on the leakage current flowing across the capacitor. It was further assumed that this current involves charged ions which undergo multiple collisions with air. These collisions transfer momentum. All of the measured data was consistent with this model. Many configurations were tested, and the results suggest general design principles for ACTs to be used for a variety of purposes.				
14. SUBJECT TERMS Interstellar travel; Spacecraft propulsion; Physics; Gravitation; Antigravity			15. NUMBER OF PAGES 22	
			16. PRICE CODE	
17. SECURITY CLASSIFICATION OF REPORT Unclassified	18. SECURITY CLASSIFICATION OF THIS PAGE Unclassified	19. SECURITY CLASSIFICATION OF ABSTRACT Unclassified	20. LIMITATION OF ABSTRACT	

